



Refrigerant gas detection module

(Model: ZP211)

User's Manual

Version: 1.1

Issue Date.2023-3-9

Zhengzhou Winsen Electronics Technology Co., Ltd

Statement

This manual's copyright belongs to Zhengzhou Winsen Electronics Technology Co., LTD. Without the written permission, any part of this manual shall not be copied, translated, stored in database or retrieval system, also can't spread through electronic, copying, record ways.

Thanks for purchasing our product. In order to let customers use it better and reduce the faults caused by misuse, please read the manual carefully and operate it correctly in accordance with the instructions.

If users disobey the terms or remove, disassemble, change the components inside of the sensor, we shall not be responsible for the loss.

The specific such as color, appearance, sizes &etc., please in kind prevail.

We are devoting ourselves to products development and technical innovation, so we reserve the right to improve the products without notice. Please confirm it is the valid version before using this manual. At the same time, users' comments on optimized using way are welcome.

Please keep the manual properly, in order to get help if you have questions during the usage in the future.

Zhengzhou Winsen Electronics Technology CO., LTD.

ZP211 Refrigerant gas detection module

Product Description

ZP211 refrigerant gas detection module adopts advanced multi-layer thick film manufacturing process semiconductor gas sensor element. The gas sensor element contains a filter adsorption layer to reduce the interference of alcohol and other gases, and has extremely high sensitivity to refrigerant gas R290. The module has been aged , calibration, calibration, with good consistency and high sensitivity.

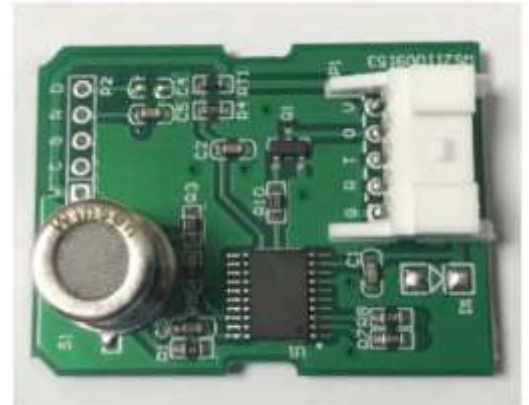

Features

High sensitivity, fast response, strong anti-interference ability, long life, stable operation, factory calibrated, sensor fault self-diagnosis

Application

Used for air conditioning, refrigeration system refrigerant leak detection.

Parameters

Model	ZP211
Target Gas	Refrigerant gas R290
Physical interface	S05B-PASK-2
Output Data	PWM
Working Voltage	5.0±0.2V DC (No voltage reverse connect protection)
Working Current	≤80mA
Warm Up Time	≤3 min
Recovery time	≤120s
Set alarm concentration	2000ppm
Initial alarm accuracy	1340~2660ppm
Operating Temperature	-20~55°C
Operating Humidity	≤95% RH
Storage Temperature	-20~60°C
Storage Humidity	≤60% RH
Size	25×34×14.1mm (L×W×H)
Weight	5g

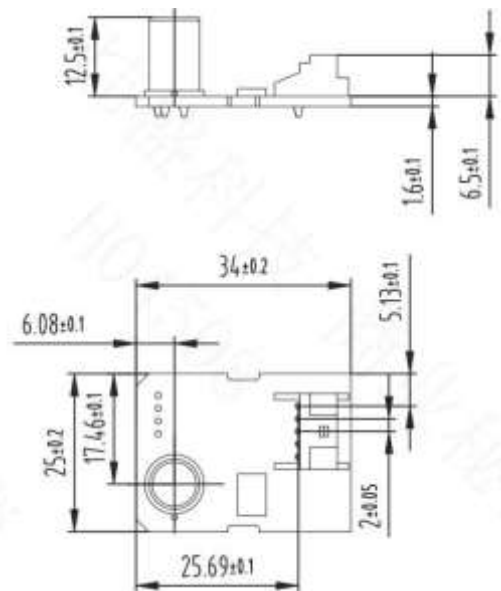

Figure 1:Structure(tolerance ±0.2mm)

Terminal definition

Pin	Name	Function
G	GND	Input power -
R	/	/
T	/	/
O	Output	PWM signal output (need to connect external pull-up resistor)
V	5V	Input power +

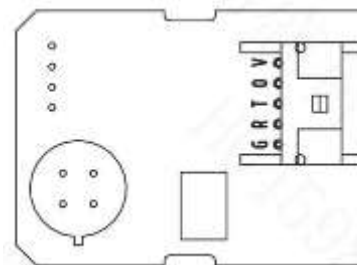

Figure 2: Module Pin Diagram

Definition of output signal

Status	PWM output	
Preheating	H: 75ms	L: 300ms
Work	H: 75ms	L: 300ms
Alarm	H: 225ms	L: 150ms
Fault	H: 300ms	L: 75ms

Note:

1. After the module enters the alarm state, it will keep the alarm state and will not switch to other states. It needs to be powered on again to exit the alarm state.
2. If the sensor is exposed to high concentrations (above 10000ppm) of R290 gas, the sensor may be damaged and its performance may be affected.
3. The module fault signal takes priority over the alarm signal.

Sensor basic testing circuit

The module uses an MP511D sensor, and Figure 3 shows the basic testing circuit of the MP511D sensor.

The sensor requires two voltages to be applied: heating voltage (VH) and testing voltage (VC).

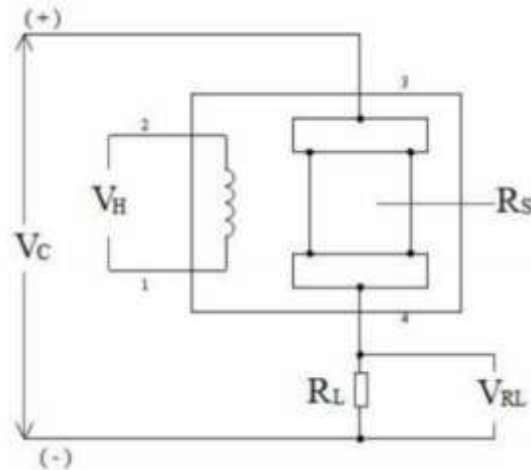

Figure 3 Basic Test Circuit of MP511D Sensor

Among them, V_H is used to provide a specific operating temperature for the sensor, and the voltage is applied to both ends of the heating electrode using a DC power supply. V_C is used to measure the circuit's loop voltage. V_{RL} is the voltage on the load resistor (R_L) connected in series with the sensor, which is the output voltage V_{OUT} . The module determines the concentration of refrigerant R290 in the current environment by detecting the voltage of V_{OUT} . On the premise of meeting the electrical characteristics of the sensor, V_H and V_C can share a common power supply circuit.

Cautions

- Please do not put the module in organic solvent (include silica gel and other cementing compound), painting, medicament, oils and fuels, high concentration gas etc.
- Please do not impact or vibrate the module seriously.
- Please warm up for 5 min before first use.
- Please do not use the module related with personal safety.
- Please do not install the module in the severe convection environment.
- Please do not put in the module in high concentration organic gas for long time.
- Please supply the module with requested voltage as manual strictly, if voltage is higher than 5.5V, the module will be destroyed irreversibly.

Zhengzhou Winsen Electronics Technology Co., Ltd

Add: No.299, Jinsuo Road, National Hi-Tech Zone, Zhengzhou
450001 China

Tel: +86-371-67169097/67169670

Fax: +86-371-60932988

E-mail: sales@winsensor.com

Website: www.winsen-sensor.com

