

SERIES 2100

Screw to screw-less terminal strips used for making faster electrical connections inside lighting and electrical appliances.



Raw materials

Moulding: Polyamide 6.6. Cream colour. V0 (according to UL94).

Insert: Steel.

Screws: Zinc-plated steel. Metric thread.



Glow-wire test 960°C according to EN 60695-2-11











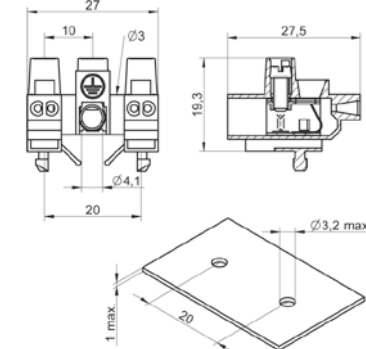



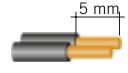

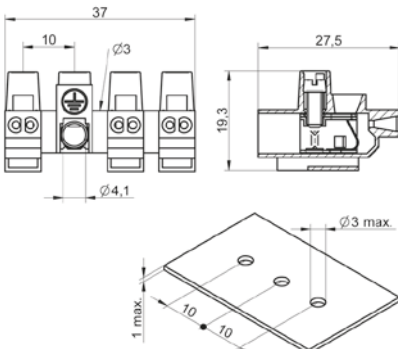















Technical features according to EN 60998

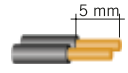



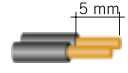

Types **2100** and **2200**: supplied in 12 ways strip. Available pre-cut and printed upon request.



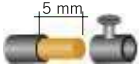
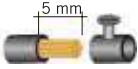
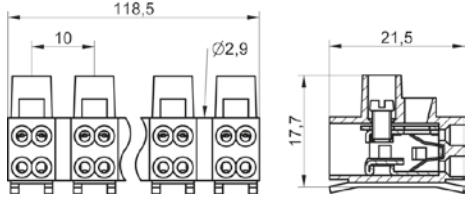

2100		200 pcs. 437x171x117 mm	6,8 Kg	
		2,5 mm ² / 1 mm ²	2 x 1,5 mm ² / 0,75 mm ²	M 3
		Voltage 450V	Current rating 24A	110°C



2102		1.000 pcs. 330x270x230 mm	9,6 Kg	
		2,5 mm ² / 1 mm ²	2 x 1,5 mm ² / 0,75 mm ²	M 3
		Voltage 450V	Current rating 24A	110°C

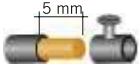
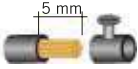
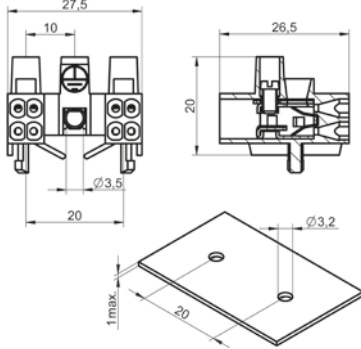

SERIES 2100

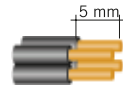
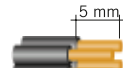
2102 A		 1.000 pcs. 330x270x230 mm  9,7 Kg
 <p>2,5 mm² / 1 mm²</p>		
 <p>2 x 1,5 mm² / 0,75 mm²</p>		<p>Voltage 450V</p> <p>Current rating 24A</p>  110°C
2103		 1.000 pcs. 330x270x230 mm  12,9 Kg
 <p>2,5 mm² / 1 mm²</p>		
 <p>2 x 1,5 mm² / 0,75 mm²</p>		<p>Voltage 450V</p> <p>Current rating 24A</p>  110°C
2103 A		 750 pcs. 330x270x230 mm  9,6 Kg
 <p>2,5 mm² / 1 mm²</p>		
 <p>2 x 1,5 mm² / 0,75 mm²</p>		<p>Voltage 450V</p> <p>Current rating 24A</p>  110°C
2104		 500 pcs. 330x270x230 mm  7,9 Kg
 <p>2,5 mm² / 1 mm²</p>		
 <p>2 x 1,5 mm² / 0,75 mm²</p>		<p>Voltage 450V</p> <p>Current rating 24A</p>  110°C
2104 A		 500 pcs. 330x270x230 mm  7,9 Kg
 <p>2,5 mm² / 1 mm²</p>		
 <p>2 x 1,5 mm² / 0,75 mm²</p>		<p>Voltage 450V</p> <p>Current rating 24A</p>  110°C

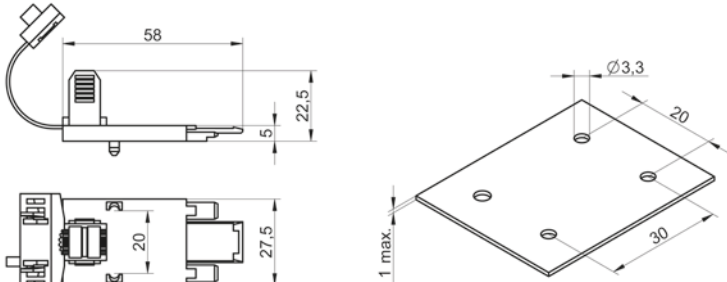
2200		 200 pcs. 480x194x144 mm		 7,4 Kg
 5 mm  5 mm 2,5 mm ² / 1 mm ²		 M 3	 12 ways	
 5 mm 4 x 1,5 mm ² / 0,5 mm ²		Voltage 450V	Current rating 24A	 85°C

2202		 1.000 pcs. 330x270x230 mm		 9,7 Kg
 5 mm  5 mm 2,5 mm ² / 1 mm ²		 M 3	Standard printing  N L	
 5 mm 4 x 1,5 mm ² / 0,5 mm ²		Voltage 450V	Current rating 24A	 85°C

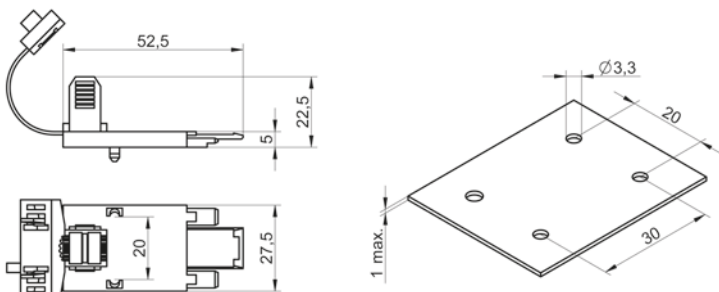
ST/1 Strain relief clamp (for clamping and fixing external conductors in lighting fixtures).			
Types 2102, 2103 and 2104			
Polyamide 6. Natural colour			
 500 pcs. 330x270x230 mm			
 2,7 Kg			

ST/2 Strain relief clamp (for clamping and fixing external conductors in lighting fixtures).			
Type 2202			
Polyamide 6. Natural colour			
 500 pcs. 330x270x230 mm			
 2,7 Kg			