

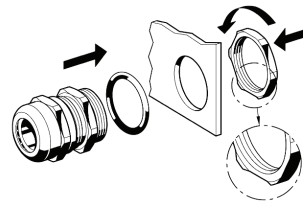

These EMC cable glands combine several advantages in one product. First, you get the same clamping ranges as the standard brass glands. The protection class is IP68. In order to get a low electrical impedance between the cable gland and the braiding of the cable the cable gland does not have to be disassembled. Secondly, a perfect shielding will be achieved by just tightening the dome nut. This high tech cable gland consists of a nickel plated brass body, PA6 clamping insert, an EMC contact element and choloprene seal. The components are pre-assembled.

To install an EMC cable gland remove approx. 5 – 10 mm (0.20 – 0.39) of the insulation in the cable. Insert the cable in to the cable gland and adjust it without the contact elements touching the braiding. Tighten the cap and conductivity will be established. The design of the contact elements will adapt to different cable diameters according to the clamping range of the cable glands. Since the clamping insert of the cable gland is as long as the gland itself electrical shortcuts between the body and individual wires will be avoided.

Tightening the dome nut will have three different effects: The cable will be centered in the cable gland, the choloprene seal will ensure IP 68 protection, and the design of the dome cap will provide appropriate strain relief. All is done by just one turn of the dome cap. Even uninstalling the cable is easy; open the dome cap and pull the cable out of the cable gland together with the insert, which can then be removed easily.



Tighten the cable gland to the housing

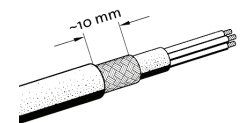

Remove outer sheath of shielded cable

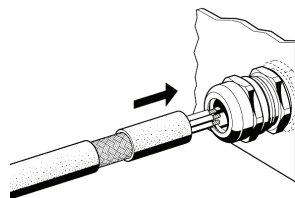

Insert cable until EMC spring.

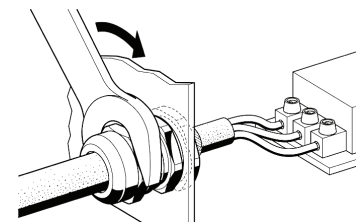

Lock and tight the cap.

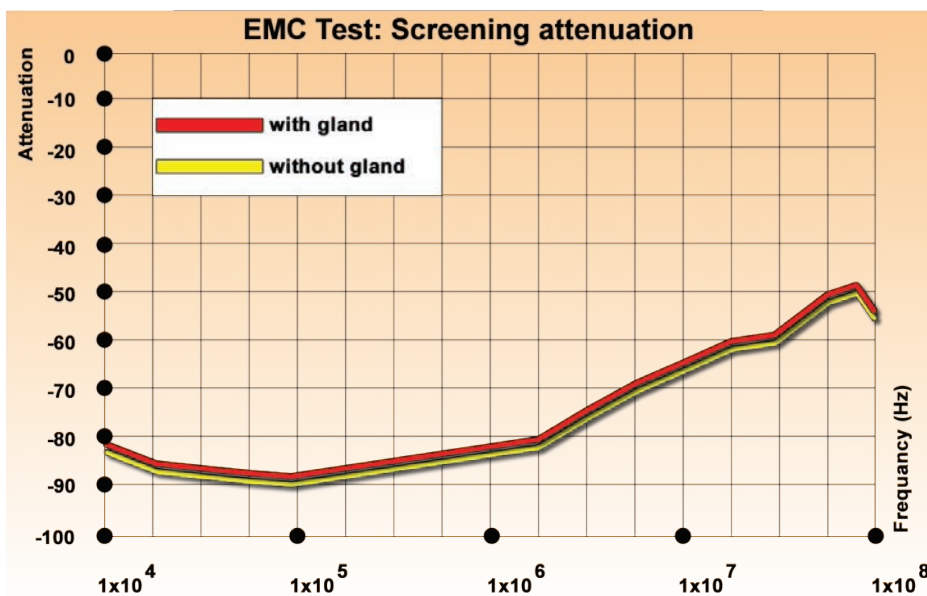
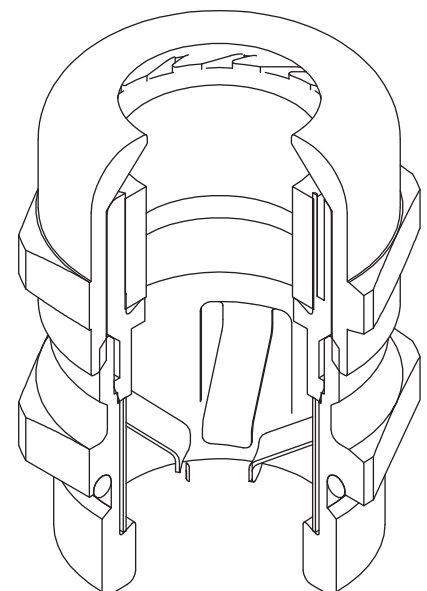

METRIC THREAD CABLE GLANDS

BMEM-BMEN

EMC 2 SERIES

Technical Details		
Material		
Body	Brass, Nickel plated	
Cap	Brass, Nickel plated	
Contact Spr.	Special Copper Alloy	
Clamp.Insert	Polyamide 6 V2	
Seal	Chloroprene	
O-ring	NBR	
Flammability	V2 (According to UL 94)	
Protection Class	IP 68 - 5 Bar	
Operating Temperature		
Permanent	-20 °C up to +100 °C	
Intermittent	-40 °C up to +150 °C	
Attachment Thread	EN 60423	

Benefits	
	Suitable for highest demands of todays technology
	Easy to assemble
	Easy handling
	Water tight
	Strain relief

Accessories	
	Lock nuts

Approvals	
	VDE, UL, UR, CSA, see page 82

Remarks	
	Manufactured according to the requirements of EN 50262

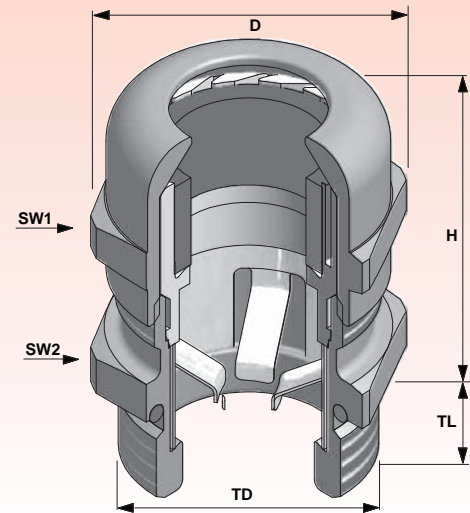

Thread Type	Technical Information								Codes	Packing Information	
	Clamping Range Ø min-max mm	Shield Diameter Ø min mm	TL mm	TD mm	SW1 mm	SW2 mm	Max. H mm	D mm		Inner Pack	Box/Min.OQ
M12X1,5	3,0 - 6,5	2,5	6,0	12,0	14,0	14,0	22,0	15,5	BMEM-0S	50	2.000
M16X1,5	4,0 - 8,0	3,0	7,0	16,0	17,0	18,0	23,0	18,9	BMEM-01	50	1.500
M16X1,5	4,5 - 10,0	3,5	6,5	16,0	20,0	20,0	24,0	22,0	BMEM-01S	50	1.500
M20X1,5	6,0 - 12,0	4,5	8,0	20,0	22,0	22,0	25,0	24,5	BMEM-02	50	800
M25X1,5	10,0 - 14,0	8,5	8,0	25,0	24,0	27,0	28,0	26,8	BMEM-03	25	500
M25X1,5	12,0 - 18,0	10,5	8,0	25,0	30,0	30,0	37,0	33,0	BMEM-03S	25	400
M32X1,5	13,0 - 18,0	11,0	9,0	32,0	30,0	34,0	33,0	33,0	BMEM-04	25	350
M32X1,5	17,0 - 24,0	14,0	8,0	32,0	40,0	40,0	35,0	41,8	BMEM-04S	25	250
M40X1,5	18,0 - 25,0	16,0	9,0	40,0	40,0	43,0	39,0	44,5	BMEM-05	20	160
M40X1,5	22,0 - 32,0	20,0	8,0	40,0	50,0	50,0	42,0	55,0	BMEM-05S	20	140
M50X1,5	22,0 - 32,0	20,0	9,0	50,0	50,0	55,0	47,0	55,5	BMEM-06	15	90
M50X1,5	30,0 - 38,0	26,0	9,0	50,0	57,0	57,0	49,0	62,7	BMEM-06S	10	70
M63X1,5	34,0 - 44,0	31,0	14,0	63,0	64,0	68,0	53,0s	70,0	BMEM-07	12	72
Glands with Long Thread											
M12X1,5	3,0 - 6,5	2,5	12,0	12,0	14,0	14,0	21,8	15,5	BMEN-0S	50	2.000
M16X1,5	4,0 - 8,0	3,0	12,0	16,0	17,0	18,0	22,6	18,9	BMEN-01	50	1.500
M20X1,5	6,0 - 12,0	4,5	12,0	20,0	22,0	22,0	24,5	24,5	BMEN-02	50	800
M25X1,5	10,0 - 14,0	8,5	12,0	25,0	24,0	27,0	27,5	26,8	BMEN-03	25	400
M32X1,5	13,0 - 18,0	11,0	15,0	32,0	30,0	34,0	33,0	33,0	BMEN-04	25	300
M40X1,5	18,0 - 25,0	16,0	15,0	40,0	40,0	43,0	39,0	44,5	BMEN-05	20	160
M50X1,5	22,0 - 32,0	20,0	15,0	50,0	50,0	55,0	47,3	55,5	BMEN-06	15	90
M63X1,5	34,0 - 44,0	31,0	18,0	63,0	64,0	68,0	52,2	70,0	BMEN-07	12	72

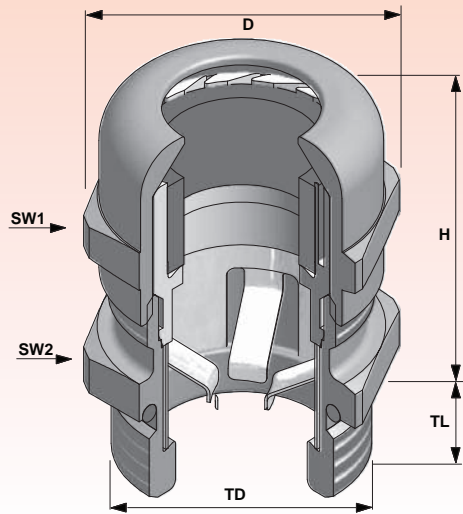

Technical Details		
Material		
Body	Brass, Nickel plated	
Cap	Brass, Nickel plated	
Contact Spr.	Special Copper Alloy	
Clamp.Insert	Polyamide 6 V2	
Seal	Chloroprene	
O-ring	NBR	
Flammability	V2 (According to UL 94)	
Protection Class	IP 68 - 5 Bar	
Operating Temperature		
Permanent	-20 °C up to +100 °C	
Intermittent	-40 °C up to +150 °C	
Attachment Thread	DIN 40430	

Benefits	
	Suitable for highest demands of todays technology
	Easy to assemble
	Easy handling
	Water tight
	Strain relief
Accessories	
	Lock nuts
Approvals	
	VDE, UL, UR, CSA, see page 82
Remarks	
	Manufactured according to the requirements of EN 50262

Technical Information										Packing Information	
Thread Type	Clamping Range Ø min-max mm	Shield Diameter Ø min mm	TL mm	TD mm	SW1 mm	SW2 mm	Max. H mm	D mm	Codes	Inner Pack	
										Box/Min.OQ	
Pg7	3,0 - 6,5	2,5	6,0	12,5	14,0	14,0	21,8	15,5	BSEM-01	50	2.000
Pg9	4,0 - 8,0	3,0	6,0	15,2	17,0	17,0	22,6	18,9	BSEM-02	50	1.500
Pg11	5,0 - 10,0	4,0	6,0	18,6	20,0	20,0	25,3	22,0	BSEM-03	50	1.000
Pg13,5	6,0 - 12,0	5,0	6,5	20,4	22,0	22,0	24,1	24,5	BSEM-04	50	800
Pg16	10,0 - 14,0	8,5	6,5	22,5	24,0	24,0	27,5	26,8	BSEM-05	25	600
Pg21	13,0 - 18,0	11,0	7,2	28,3	30,0	30,0	31,2	33,0	BSEM-06	25	350
Pg29	18,0 - 25,0	16,0	8,0	37,0	40,0	40,0	39,3	44,5	BSEM-07	20	160
Pg36	22,0 - 32,0	20,0	9,0	47,0	50,0	50,0	47,2	55,5	BSEM-08	15	90
Pg42	30,0 - 38,0	28,0	12,0	54,0	58,0	58,0	47,7	64,0	BSEM-09	12	72
Pg48	34,0 - 44,0	31,0	14,0	59,3	64,0	64,0	52,0	70,0	BSEM-10	12	72
Glands with Long Thread											
Pg7	3,0 - 6,5	2,5	8,0	12,5	14,0	14,0	21,8	15,5	BSEN-01	50	2.000
Pg9	4,0 - 8,0	3,0	10,0	15,2	17,0	17,0	22,6	18,9	BSEN-02	50	1.500
Pg11	5,0 - 10,0	4,0	10,0	18,6	20,0	20,0	25,3	22,0	BSEN-03	50	1.000
Pg13,5	6,0 - 12,0	5,0	10,0	20,4	22,0	22,0	24,1	24,5	BSEN-04	50	800
Pg16	10,0 - 14,0	8,5	10,0	22,5	24,0	24,0	27,5	26,8	BSEN-05	25	500
Pg21	13,0 - 18,0	11,0	12,0	28,3	30,0	30,0	31,2	33,0	BSEN-06	25	350
Pg29	18,0 - 25,0	16,0	12,0	37,0	40,0	40,0	39,3	44,5	BSEN-07	20	160
Pg36	22,0 - 32,0	20,0	14,0	47,0	50,0	50,0	47,2	55,5	BSEN-08	15	90
Pg42	30,0 - 38,0	28,0	16,0	54,0	58,0	58,0	47,7	64,0	BSEN-09	12	72
Pg48	34,0 - 44,0	31,0	18,0	59,3	64,0	64,0	52,0	70,0	BSEN-10	12	72

NPT THREAD CABLE GLANDS

BNEM

EMC 2 SERIES

Technical Details		
Material		
Body	Brass, Nickel plated	
Cap	Brass, Nickel plated	
Contact Spr.	Special Copper Alloy	
Clamp.Insert	Polyamide 6 V2	
Seal	Chloroprene	
O-ring	NBR	
Flammability	V2 (According to UL 94)	
Protection Class	IP 68 - 5 Bar	
Operating Temperature		
Permanent	-20 °C up to +100 °C	
Intermittent	-40 °C up to +150 °C	
Attachment Thread	ANSI B1.20.1	

Benefits	
	Suitable for highest demands of todays technology
	Easy to assemble
	Easy handling
	Water tight
	Strain relief

Accessories	
	Lock nuts

Approvals	
	VDE, UL, UR, CSA, see page 82

Remarks	
	Manufactured according to the requirements of EN 50262

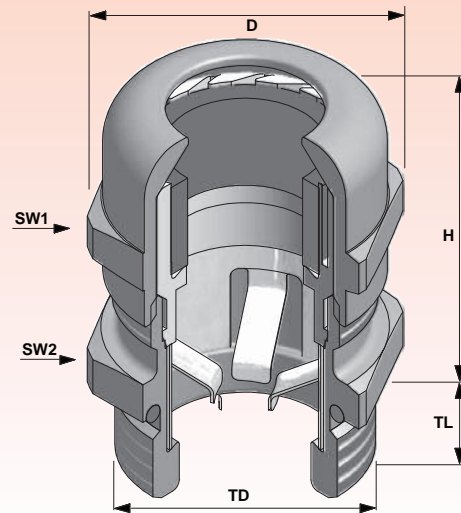

Thread Type	Technical Information								Codes	Packing Information	
	Clamping Range Ø min-max inch	Shield Diameter Ø min inch	TL inch	TD inch	SW1 inch	SW2 inch	Max. H inch	D inch		Inner Pack	Box/Min.OQ
NPT3/8"	0,196 - 0,393	0,157	0,452	0,669	0,787	0,787	1,594	0,866	BNEM-01	50	1.000
NPT1/2"	0,236 - 0,472	0,196	0,511	0,834	0,866	0,866	1,507	0,964	BNEM-02	50	800
NPT3/4"	0,511 - 0,708	0,433	0,511	1,043	1,181	1,181	1,866	1,299	BNEM-03	25	300
NPT1"	0,708 - 0,984	0,629	0,511	1,307	1,574	1,692	2,173	1,751	BNEM-04	10	160



New generation of EMC and Derivation Gland

The new generation of Bimed's EMC and derivation gland shows significant advantages compared to other existing cable glands. The patented contact system inside the gland allows all degrees of freedom which are necessary to install a cable easily; the cable can be pulled forward and backward inside the gland without damaging the cable shielding. This is realized by specially designed contact elements. This feature is most advantageous when connectorizing the single cores of the cable.

Also the cable can easily be rotated inside the gland without damaging the cable shielding – most important when installing the gland at an industrial connector. The unique mechanism of the integrated contact system therefore shows the following features:

For small cable diameters in the lower clamping range of the gland the contact system won't touch the cable braiding during the installation process at all. For bigger cable diameters in the upper clamping range of the gland, the contact system will rotate freely inside the gland together with the cable itself. Only when tightening the cap the contact element will be fixed and will be pressed against the cable shielding to ensure a low resistance electrical contact between gland and cable braiding. Simultaneously IP68 protection class and cable anchorage according to the EN 50262 is achieved.

This straightforward application and convenient installation of the gland saves a lot of time and therefore a lot of money. Shielding and derivation tests performed with this gland show exceptional values. So this EMC and derivation gland from Bime will be used wherever an outstanding performance is needed. Simple application, fast installation together with the patented contact system makes Bimed's gland unique among the cable glands.

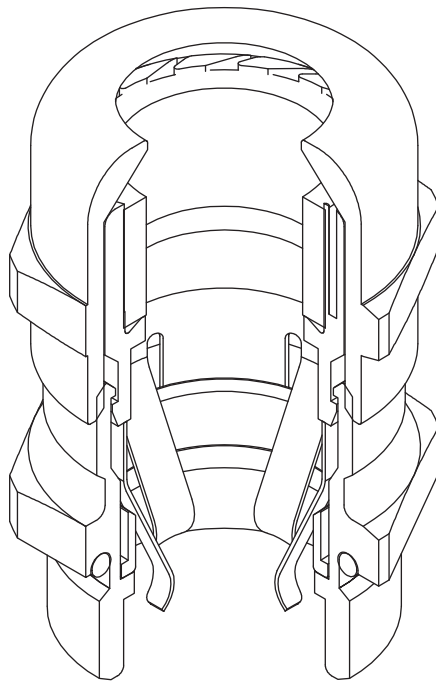

EURO METRIC THREAD CABLE GLANDS

BMEM-E

EMC 3 SERIES

Technical Details		
Material		
Body	Brass, Nickel plated	
Cap	Brass, Nickel plated	
Contact Spr.	Special Copper Alloy	
Clamp.Insert	Polyamide 6 V2	
Seal	Chloroprene	
O-ring	NBR	
Flammability	V2 (According to UL 94)	
Protection Class	IP 68 - 5 Bar	
Operating Temperature		
Permanent	-20 °C up to +100 °C	
Intermittent	-40 °C up to +150 °C	
Attachment Thread	EN 60423	

Benefits	
	Suitable for highest demands of todays technology
	Easy to assemble
	Easy handling
	Water tight
	Strain relief

Accessories	
	Lock nuts

Approvals	
	VDE, UL, UR, CSA, see page 82

Remarks	
	Fast and easy installation.
	Adapts to different cable shields.
	Reliable connection.
	High shielding factor.
	Mechanical values according to EN 50262.
	Clamping range identical to all other Eurometric Bime glands.
	360° brand touching.
	Manufactured according to the requirements of EN 50262

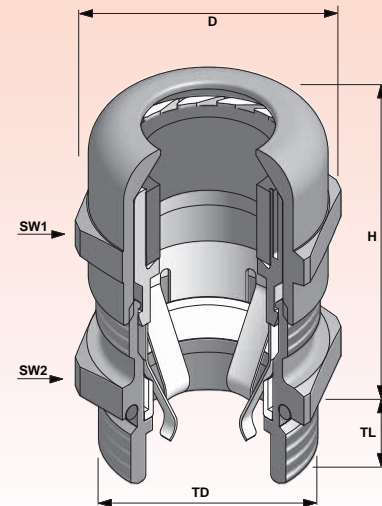

Thread Type	Technical Information								Codes	Packing Information	
	Clamping Range Ø min-max mm	Shield Diameter Ø min mm	TL mm	TD mm	SW1 mm	SW2 mm	Max. H mm	D mm		Inner Pack	Box/Min.OQ
M12X1,5	3,0 - 6,5	2,5	6,0	12,0	14,0	14,0	21,5	15,5	BMEM-ES	50	2.000
M16X1,5	5,0 - 10,0	4,0	7,0	16,0	20,0	20,0	25,3	22,0	BMEM-E1	50	1.000
M20X1,5	6,0 - 12,0	5,0	8,0	20,0	22,0	22,0	26,5	24,5	BMEM-E2	50	800
M25X1,5	11,0 - 17,0	9,5	8,0	25,0	27,0	27,0	32,7	30,0	BMEM-E3	25	400
M32X1,5	15,0 - 21,0	13,5	8,0	32,0	34,0	34,0	36,3	37,0	BMEM-E4	25	250
M40X1,5	19,0 - 28,0	17,0	9,0	40,0	43,0	43,0	44,5	48,4	BMEM-E5	20	140
M50X1,5	27,0 - 38,0	25,0	9,0	50,0	58,0	58,0	51,5	64,0	BMEM-E6	12	72
M63X1,5	34,0 - 44,0	31,0	14,0	63,0	64,0	68,0	52,9	70,0	BMEM-E7	12	72

These cable glands are developed according to end users' requirements. Their features can be summarized as follows:

- Easy insertion of the cable from the two sides of the gland.
- Open contact fingers in loose position.
- Free radial and axial movement of the cable.
- Easy radial and axial movement of the cable, even in contact position without any damage to the braid with the help of rounded contact finger surfaces.
- Large contact surfaces of the fingers allow low contact resistance even on loosely woven cable braids (the contact surfaces do not sink into the braided wires).
- High contact performance even under vibrating conditions with help of the reduced **A2** distance between the "sealing clamping level" and "EMC contact level".

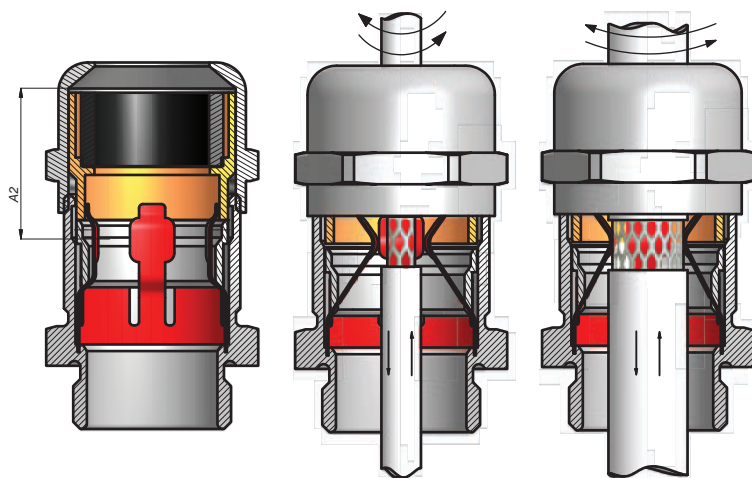
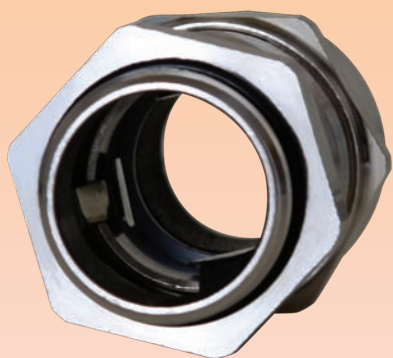

As Supplied

With Min. Cable Diameter

With Max. Cable Diameter

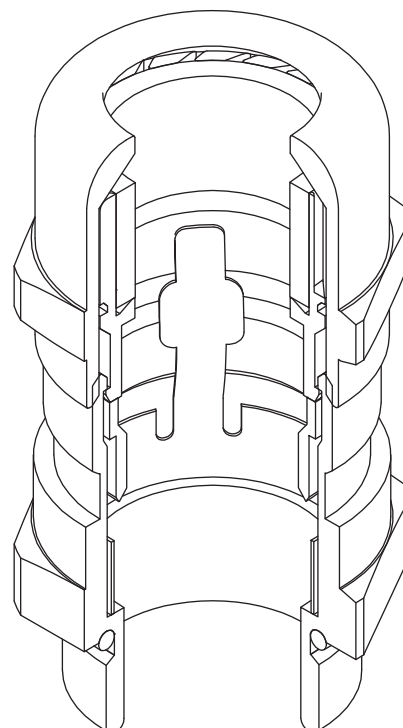

METRIC THREAD CABLE GLANDS

BMEM-E

EMC 4 SERIES

Technical Details		
Material		
Body	Brass, Nickel plated	
Cap	Brass, Nickel plated	
Contact Spr.	Special Copper Alloy	
Clamp.Insert	Polyamide 6 V2	
Seal	Chloroprene	
O-ring	NBR	
Flammability	V2 (According to UL 94)	
Protection Class	IP 68 - 5 Bar	
Operating Temperature		
Permanent	-20 °C up to +100 °C	
Intermittent	-40 °C up to +300 °C	
Attachment Thread	EN 60423	

Benefits	
	Suitable for highest demands of todays technology
	Easy to assemble
	Easy handling
	Water tight
	Strain relief

Accessories	
	Lock nuts

Approvals	
	VDE, UL, UR, CSA, see page 82

Remarks	
	Manufactured according to the requirements of EN 50262

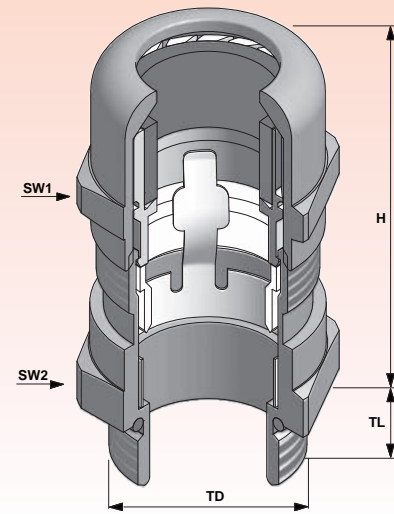

Thread Type	Technical Information							Codes	Packing Information	
	Clamping Range Ø min-max mm	Shield Diameter Ø min mm	TL mm	TD mm	SW1 mm	SW2 mm	Max. H mm		Inner Pack	Box/Min. OQ
M12X1,5	3,0 - 6,5	2,0 - 5,0	6,0	12	14,0	14,0	28,0	BMEM-E5 (M12T)	50	2.000
M16X1,5	5,0 - 10,0	3,5 - 8,0	6,0	16	20,0	20,0	34,0	BMEM-E1 (M16T)	50	1.000
M20X1,5	6,0 - 12,0	4,5 - 10,0	6,0	20	22,0	22,0	32,0	BMEM-E2S (M20T)	50	800
M20X1,5	7,5 - 14,0	5,5 - 11,5	8,0	20	24,0	24,0	38,0	BMEM-E2 (M20T)	50	600
M25X1,5	10,0 - 18,0	7,0 - 14,0	8,0	25	30,0	30,0	42,0	BMEM-E3 (M25T)	25	400
M32X1,5	16,0 - 25,0	12,0 - 20,0	9,0	32	40,0	40,0	50,0	BMEM-E4 (M32T)	25	250
M40X1,5	22,0 - 32,0	18,0 - 27,0	9,0	40	50,0	50,0	57,0	BMEM-E5 (M40T)	20	140
M50X1,5	30,0 - 38,0	26,0 - 34,0	9,0	50	58,0	58,0	67,0	BMEM-E6 (M50T)	10	100
M63X1,5	34,0 - 44,0	30,0 - 40,0	14,0	63	64,0	68,0	69,0	BMEM-E7 (M63T)	5	50
M63X1,5	37,0 - 53,0	33,0 - 49,0	10,0	63	75,0	75,0	72,0	BMEM-E7L (M63T)	2	20

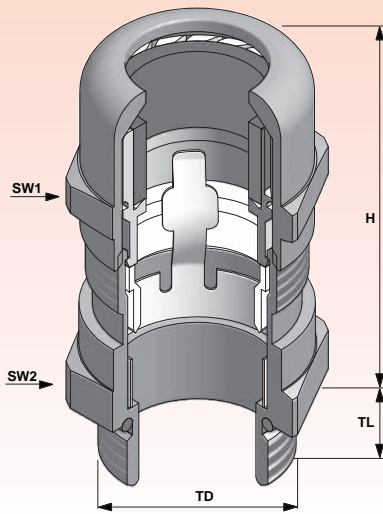

Technical Details		
Material		
Body	Brass, Nickel plated	
Cap	Brass, Nickel plated	
Contact Spr.	Special Copper Alloy	
Clamp.Insert	Polyamide 6 V2	
Seal	Chloroprene	
O-ring	NBR	
Flammability	V2 (According to UL 94)	
Protection Class	IP 68 - 5 Bar	
Operating Temperature		
Permanent	-20 °C up to +100 °C	
Intermittent	-40 °C up to +300 °C	
Attachment Thread	DIN 40430	

Benefits	
	Suitable for highest demands of todays technology
	Easy to assemble
	Easy handling
	Water tight
	Strain relief

Accessories	
	Lock nuts

Approvals	
	VDE, UL, UR, CSA, see page 82

Remarks	
	Manufactured according to the requirements of EN 50262
	These ranges are not kepted in our stocks and can be produced only for 2.000 pcs as MOQ.

Technical Information								Codes	Packing Information	
Thread Type	Clamping Range Ø min-max mm	Shield Diameter Ø min mm	TL mm	TD mm	SW1 mm	SW2 mm	Max. H mm		Inner Pack	Box/Min. OQ
Pg7	3,0 - 6,5	2,0 - 5,0	6,0	12,50	14,0	14,0	22,0	BSEM-E1(Pg7T)	50	2000
Pg9	4,0 - 8,0	3,0 - 4,0	6,0	15,20	17,0	17,0	23,0	BSEM-E2 (Pg9T)	50	1500
Pg11	5,0 - 10,0	3,5 - 8,0	6,0	18,60	20,0	20,0	28,0	BSEM-E3(Pg11T)	50	1.000
Pg13,5	6,0 - 12,0	4,5 - 10,0	6,0	20,40	22,0	22,0	26,0	BSEM-E4(Pg13,5T)	50	800
Pg16	7,5 - 14,0	5,5 - 11,5	8,0	22,50	24,0	24,0	30,0	BSEM-E5 (Pg16T)	25	600
Pg21	10,0 - 18,0	7,0 - 14,0	8,0	28,30	30,0	30,0	34,0	BSEM-E6 (Pg21T)	25	400
Pg29	16,0 - 25,0	12,0 - 20,0	9,0	37,00	40,0	40,0	41,0	BSEM-E7 (Pg29T)	25	250
Pg36	22,0 - 32,0	18,0 - 27,0	9,0	47,00	50,0	50,0	48,0	BSEM-E8 (Pg36T)	20	140
Pg42	30,0 - 38,0	26,0 - 34,0	9,0	54,00	58,0	60,0	49,0	BSEM-E9 (Pg42T)	10	100
Pg48	34,0 - 44,0	30,0 - 40,0	14,0	59,30	64,0	68,0	52,0	BSEM-E0 (Pg48T)	5	50

NPT THREAD CABLE GLANDS

BNEM-E

EMC 4 SERIES

Technical Details		
Material		
Body	Brass, Nickel plated	
Cap	Brass, Nickel plated	
Contact Spr.	Special Copper Alloy	
Clamp.Insert	Polyamide 6 V2	
Seal	Chloroprene	
O-ring	NBR	
Flammability	V2 (According to UL 94)	
Protection Class	IP 68 - 5 Bar	
Operating Temperature		
Permanent	-20 °C up to +100 °C	
Intermittent	-40 °C up to +300 °C	
Attachment Thread	ANSI B1.20.1	

Benefits	
	Suitable for highest demands of todays technology
	Easy to assemble
	Easy handling
	Water tight
	Strain relief

Accessories	
	Lock nuts

Approvals	
	VDE, UL, UR, CSA, see page 82

Remarks	
	Manufactured according to the requirements of EN 50262 These ranges are not kept in our stocks and can be produced only for 2.000 pcs as MOQ.

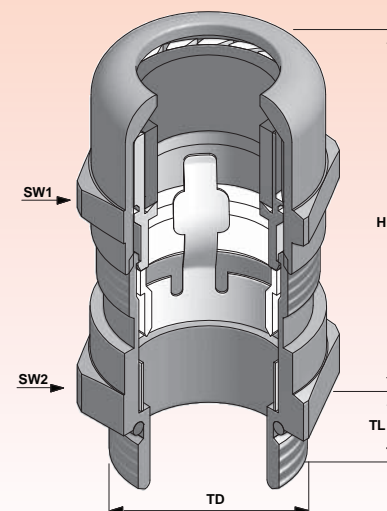

Thread Type	Technical Information						Codes	Packing Information	
	Clamping Range Ø min-max inch	Shield Diameter Ø min inch	TL inch	SW1 inch	SW2 inch	Max. H inch		Inner Pack	Box/Min. OQ
NPT 1/4"	0,118 - 0,255	0,078 - 0,196	0,236	0,551	0,551	1,102	BNEM-E5 (NPT1/4"T)	50	2.000
NPT 3/8"	0,196 - 0,393	0,137 - 0,314	0,236	0,787	0,787	1,338	BNEM-E1 (NPT3/8"T)	50	1.000
NPT 1/2"	0,236 - 0,472	0,177 - 0,393	0,314	0,866	0,866	1,259	BNEM-E2S (NPT1/2"T)	50	800
NPT 1/2"	0,295 - 0,551	0,216 - 0,452	0,314	0,944	0,944	1,496	BNEM-E2 (NPT1/2"T)	50	600
NPT 3/4"	0,393 - 0,708	0,275 - 0,551	0,314	1,181	1,181	1,653	BNEM-E3 (NPT3/4"T)	25	400
NPT 1"	0,629 - 0,984	0,472 - 0,787	0,354	1,574	1,574	1,968	BNEM-E4 (NPT1"T)	25	250
NPT 1 1/4"	0,866 - 1,259	0,708 - 1,062	0,354	1,968	1,968	2,244	BNEM-E5 (NPT1 1/4"T)	20	140
NPT 1 1/2"	1,181 - 1,889	1,023 - 1,338	0,354	2,283	2,362	2,637	BNEM-E6 (NPT1 1/2"T)	10	100
NPT 2"	1,338 - 1,732	1,181 - 1,574	0,551	2,519	2,677	2,716	BNEM-E7 (NPT2"T)	5	50

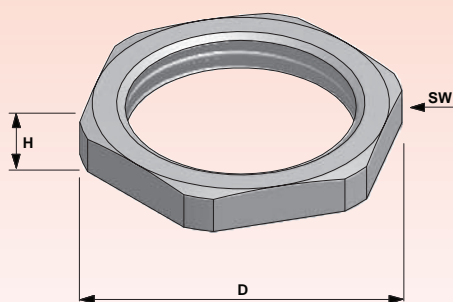

Technical Details	
Material	Lock Nut Brass, Nickel plated

Technical Information				Codes	Packing Information
Thread Type	SW mm	H mm	D mm		Inner Pack
Metric Thread (Attachment thread : EN 60423)					
M12X1,5	15	2,8	16,6	BMBL-01	100
M16X1,5	19	3,0	21,0	BMBL-02	100
M20X1,5	24	3,5	26,5	BMBL-03	100
M25X1,5	30	4,0	33,0	BMBL-04	100
M32X1,5	36	5,0	39,5	BMBL-05	50
M40X1,5	46	5,0	51,0	BMBL-06	50
M50X1,5	60	5,0	66,0	BMBL-07	10
M63X1,5	70	6,0	77,0	BMBL-08	10
M72X2,0	77	7,0	86,0	BMBL-09	10
M75X2,0	80	7,0	89,6	BMBL-10	5
M80X2,0	90	8,0	99,3	BMBL-11	5
M85X2,0	95	8,0	106,2	BMBL-12	5
M90X2,0	100	8,0	112,0	BMBL-13	5
Pg Thread (Attachment thread : DIN 40430)					
Pg 7	15	2,8	16,6	BSL-01	100
Pg 9	18	2,8	20,0	BSL-02	100
Pg 11	21	3,0	23,5	BSL-03	100
Pg 13,5	23	3,0	25,5	BSL-04	100
Pg 16	26	3,0	29,0	BSL-05	100
Pg 21	32	3,5	35,5	BSL-06	100
Pg 29	41	4,0	45,0	BSL-07	50
Pg 36	51	5,0	56,0	BSL-08	25
Pg 42	60	5,0	66,0	BSL-09	10
Pg 48	64	5,5	70,5	BSL-10	10
G(Pf) Thread (Attachment thread : DIN ISO 228)					
G 3/8"	22	5,0	24,5	BPFL-01	100
G 1/2"	27	5,0	30,0	BPFL-02	100
G 3/4"	33	5,0	36,5	BPFL-03	100
G 1"	43	5,0	46,5	BPFL-04	50



LOCK NUTS

BMEL-BSEL

EMC SERIES

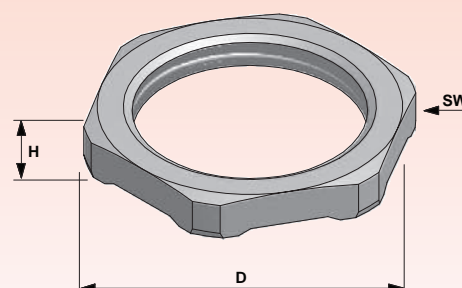
Technical Details	
Material	Lock Nut Brass, Nickel plated
Remarks	
Special design shape for painted enclosures.	



Technical Information				Codes	Packing Information
Thread Type	 SW mm	H mm	D mm		 Inner Pack
Metric Thread (Attachment thread : EN 60423)					
M12X1,5	15	3,3	16,6	BMEL-01	50
M16X1,5	19	3,5	21,0	BMEL-02	50
M20X1,5	24	3,5	26,5	BMEL-03	50
M25X1,5	30	3,5	33,0	BMEL-04	25
M32X1,5	36	4,0	39,5	BMEL-05	25
M40X1,5	46	4,6	51,0	BMEL-06	20
M50X1,5	60	5,6	66,0	BMEL-07	15
M63X1,5	70	6,7	77,0	BMEL-08	12
Pg Thread (Attachment thread : DIN 40430)					
Pg7	15	3,3	16,6	BSEL-01	50
Pg9	18	3,3	20,0	BSEL-02	50
Pg11	21	3,5	23,5	BSEL-03	50
Pg13,5	23	3,5	25,5	BSEL-04	50
Pg16	26	3,5	29,0	BSEL-05	25
Pg21	32	4,0	35,5	BSEL-06	25
Pg29	41	4,6	45,0	BSEL-07	20
Pg36	51	5,6	56,0	BSEL-08	15
Pg42	60	5,6	66,0	BSEL-09	12
Pg48	64	6,1	70,5	BSEL-10	12